

LEADWARRIOR  
HISTORICAL MINIATURE

WWW.LEADWARRIOR.COM  
INFO@LEADWARRIOR.COM  
Ebay: LEADWARRIOR

## 2cm Flak 38 auf mittlere Schutzenpanzerwagen Sd.Kfz. 251/17 Late ( Wehrmacht Type )

36 RESIN PARTS  
+ PHOTOETCH

1:35 CONVERSION KIT

for DRAGON Sd.Kfz.251/1 Ausf. D  
and any Flak 38



The Sd.Kfz.251/17 Wehrmacht Type (though some sources name this vehicle Sd.Kfz.30, Sd.Kfz.11, or Sd.Kfz.261) was one of many conversions, utilizing the Sd.Kfz.251 halftrack chassis and Flak.30/38 Anti-Aircraft Gun.

One of them was "Luftwaffe-Fla ausfuehrung" (Air force anti-aircraft version) - the most photographed, although very few were constructed.

This kit presents the later version of such a vehicle designed for Wehrmacht. It was a hybrid - the front section and chassis is Sd.Kfz.251, behind the drivers seat the armour is newly designed to protect the seated crew and the ammo. It resembles the earlier unarmored platforms at the rear on the soft skinned halftracks.

Auto-Union A.G. of Chemnitz is awarded contract number 4911-021300306/42 to produce 2400 superstructures at the Horch assembly plant in Zwickau. March 1944 sees the first 5 completed. At the end of February 1945 a total of 604 are produced. Production continued in March April and May, but production statistics didn't survive. The target was 50 a month. It is seen on west and east front.

Already in 1941 the 2-cm FlaK 38 gun proved not capable to penetrate the Russian armored planes, such as Il-2. Therefore it was produced almost throughout the war.

Most likely, as with other vehicles utilizing 2cm guns, Sd.Kfz.251/17 was used most often against ground targets.

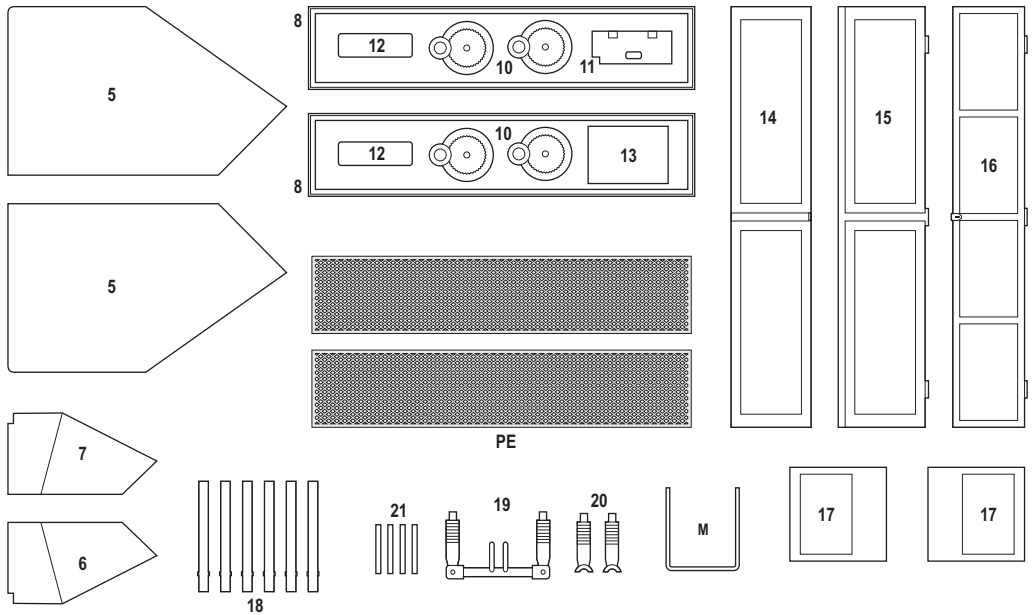
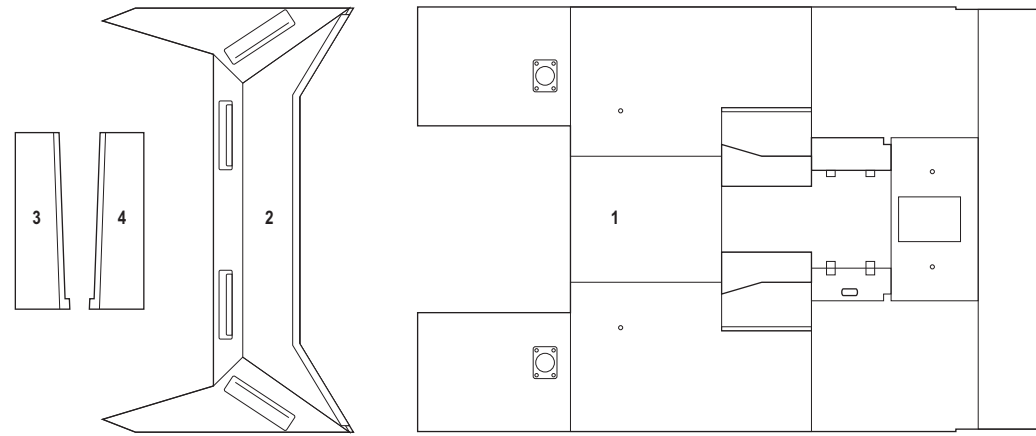

Cut / Remove

Repeat on mirror side

Optional

Repeat several times

**STUDY THE INSTRUCTION CAREFULLY BEFORE ASSEMBLING.  
TEST FIT PARTS TOGETHER BEFORE CEMENTING.  
USE CYANOACRYLATE GLUE FOR METAL AND RESIN PARTS.**

**1** Dragon parts reworking

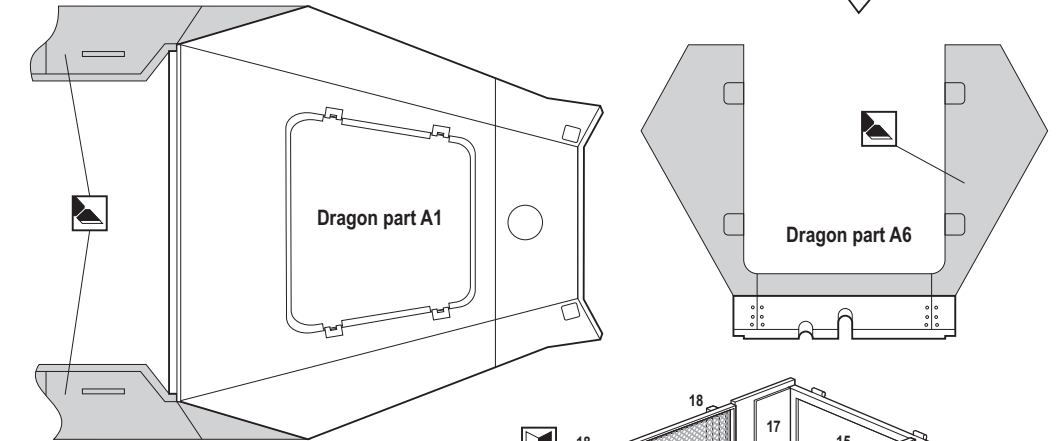
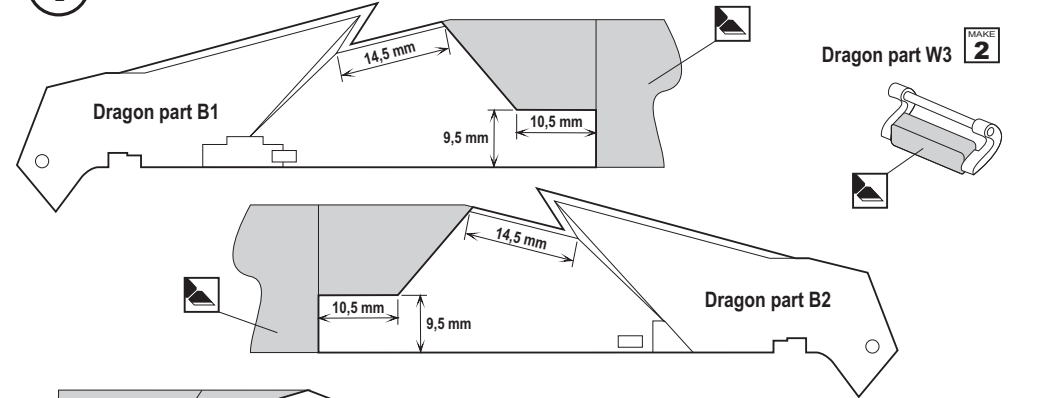

**2**

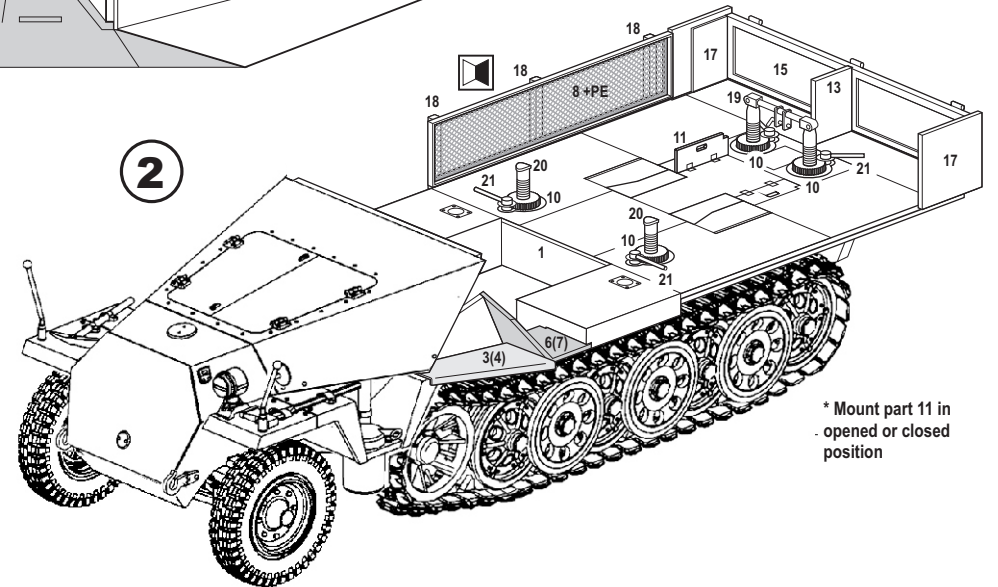

\* Mount part 11 in opened or closed position